

Max. Power kW(HP) / rpm	Max. Torque N.m(kg.m) / rpm	After-treatment
55.4(74.3) / 2600	320(32.6) / 1600	DOC + DPF
50.3(68.0) / 2600	252(25.7) / 1800	
41.0(55.0) / 2600	204(20.8) / 1800	
36.6(49.0) / 2600	182(18.6) / 1800	

**CERTIFIED  
STAGE V**



### ◆ General Engine Data

• Engine Type	In-line, 4-cycle
• Number of cylinders	4
• Displacement	2.392 liter
• Bore x Stroke	90 x 94 mm
• Compression ratio	17.0 : 1
• Firing order	1 - 3 - 4 - 2
• Aspiration	Turbocharged and air-to-air aftercooled
• Combustion System	Direct injection
• Rotation	Counter clockwise viewed from Flywheel
• Clutch	SAE#3-11.5", SAE#4-10" (SAE J620)
• Dry weight	250 kg (with after-treatment) 335 kg (with powerpack)
• Front PTO	100% Engine torque available at 2300 rpm
• Side PTO	Continuous 110Nm (SAE A)
• Valve System Type	Over head valve
• Number of Valves	Intake 2, exhaust 2 per cylinder Hydraulic Valve Lash Adjust

### ◆ Engineering Data

• Water flow	120 liters/min @2,600 rpm (74HP)
• Heat rejection	
- to coolant	10 kcal/sec @2,600 rpm (74HP) 9.8 kcal/sec @2,600 rpm (68HP) 7.9 kcal/sec @2,600 rpm (55HP)
- to CAC	1.7 kcal/sec @2,600 rpm (74HP) 1.7 kcal/sec @2,600 rpm (68HP) 1.5 kcal/sec @2,600 rpm (55HP)
• Air flow	3,810 liter/min @2,600 rpm (74HP) 3,730 liter/min @2,600 rpm (68HP) 3,580 liter/min @2,600 rpm (55HP)
• Exhaust gas temp	750 °C↓ @2,600 rpm
• Max. permission restrictions	
- Intake system	3.0 kPa clean filter 6.5 kPa dirty filter
- Exhaust system	15 kPa max.

(Please see an Installation Guide for the detail information.)

### ◆ Electrical System

• Alternator	12V x 110A / 12V x 140A
• Voltage regulator	Built-in type IC regulator
• Starting motor	12V x 2.5kW
• Battery voltage	12V
• Battery capacity	100 Ah, 750CCA (recommended)
• Starting Aid	Glow plug

### ◆ Cooling System

• Cooling method	Fresh water forced circulation
• Water capacity	3.8 liters (engine only) 8.4 liters (with powerpack)
• Water pump	Centrifugal type driven by belt
• Cooling fan	Suction/Blower type, Ø420 (optional)
• Water temperature	110°C (max.)

### ◆ Fuel System

• Injection pump	Bosch Common-rail Pump
• Governor	Controlled by ECU
• Fuel filter	Full flow, cartridge type
• Used fuel	Ultra-Low Sulfur Diesel, HVO, GTL
• Diesel consumption	218 @2,600 rpm, 214 @1,600 rpm (74HP)
(g/kWh)	220 @2,600 rpm, 212 @1,800 rpm (68HP) 225 @2,600 rpm, 211 @1,800 rpm (55HP) 232 @2,600 rpm, 211 @1,800 rpm (49HP)

### ◆ Lubrication System

• Oil filter	Full flow, cartridge type
• Lub. Method	Fully forced pressure feed type
• Oil pan capacity	High level 8.6 liters Low level 4.5 liters
• Angularity limit	35 deg all around
• Lubrication oil	10W30/40 (API CK-4 / ACEA E6)
• Maximum oil temp	135°C at main oil gallery
• Lub oil pressure	Idle Speed : Min 100 kPa

**55.4kW (74.3HP) @2600**

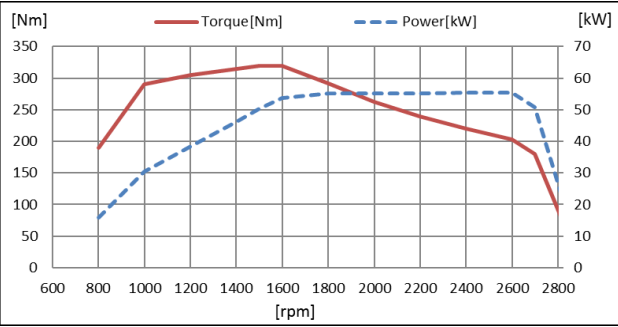

speed	Power			Torque	
	kW	PS	HP	Nm	kgm
800	15.9	21.6	21.3	190.0	19.4
1000	30.4	41.3	40.7	290.0	29.6
1200	38.3	52.1	51.4	305.0	31.1
1400	46.2	62.8	61.9	315.0	32.1
1500	50.3	68.3	67.4	320.0	32.6
1600	53.6	72.9	71.9	320.0	32.6
1800	55.0	74.8	73.8	292.0	29.8
2000	55.1	74.9	73.9	263.0	26.8
2200	55.1	74.9	73.8	239.0	24.4
2400	55.3	75.2	74.1	220.0	22.4
2600	55.4	75.3	74.3	203.5	20.8
2700	50.9	69.2	68.2	180.0	18.4
2800	26.4	35.9	35.4	90.0	9.2

**50.7kW (68.0HP) @2600**

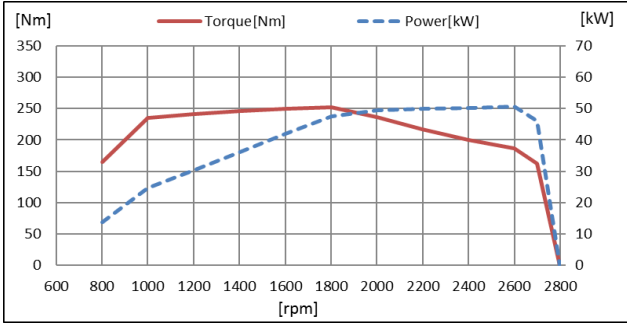

speed	Power			Torque	
	kW	PS	HP	Nm	kgm
800	13.8	18.8	18.5	165.0	16.8
1000	24.6	33.5	33.0	235.0	24.0
1200	30.3	41.2	40.6	241.0	24.6
1400	36.1	49.0	48.4	246.0	25.1
1600	41.9	57.0	56.2	250.0	25.5
1800	47.5	64.6	63.7	252.0	25.7
2000	49.4	67.2	66.3	236.0	24.1
2200	50.0	68.0	67.0	217.0	22.1
2400	50.3	68.3	67.4	200.0	20.4
2600	50.7	68.9	68.0	186.2	19.0
2700	46.0	62.6	61.7	162.8	16.6

**41.0kW (55.0HP) @2600**

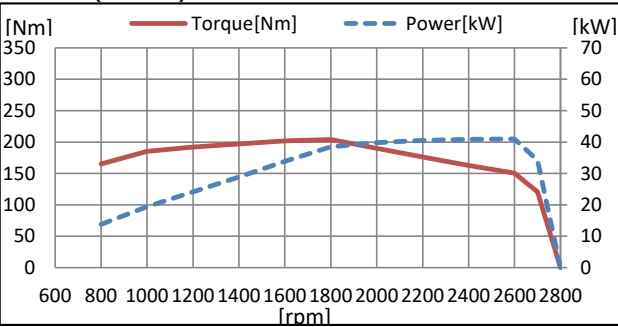

speed	Power			Torque	
	kW	PS	HP	Nm	kgm
800	13.8	18.8	18.5	165.0	16.8
1000	19.4	26.3	26.0	185.0	18.9
1200	24.1	32.8	32.4	192.0	19.6
1400	28.9	39.3	38.7	197.0	20.1
1600	33.8	46.0	45.4	202.0	20.6
1800	38.5	52.3	51.6	204.0	20.8
2000	39.8	54.1	53.4	190.0	19.4
2200	40.5	55.1	54.4	176.0	17.9
2400	40.8	55.5	54.8	162.5	16.6
2600	41.0	55.7	55.0	150.5	15.3
2700	34.2	46.4	45.8	120.8	12.3

**36.6kW (49.0HP) @2600**

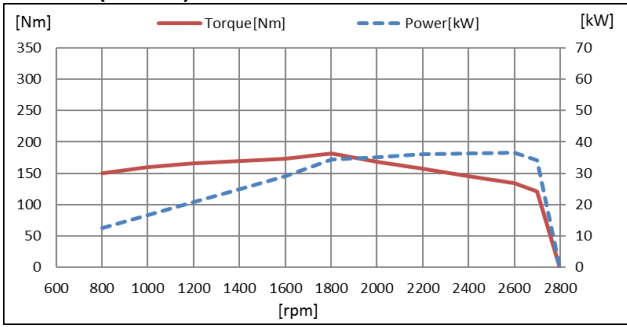

speed	Power			Torque	
	kW	PS	HP	Nm	kgm
800	12.6	17.1	16.9	150.0	15.3
1000	16.8	22.8	22.5	160.0	16.3
1200	20.9	28.4	28.0	166.0	16.9
1400	24.9	33.9	33.4	170.0	17.3
1600	29.0	39.4	38.9	173.0	17.6
1800	34.3	46.6	46.0	182.0	18.6
2000	35.2	47.8	47.2	168.0	17.1
2200	36.2	49.2	48.5	157.0	16.0
2400	36.4	49.5	48.9	145.0	14.8
2600	36.6	49.7	49.0	134.3	13.7
2700	34.2	46.4	45.8	120.8	12.3

## ◆ Engine Dimension

- Dimension (L×W×H) 857 × 576 × 724 mm (with after-treatment)

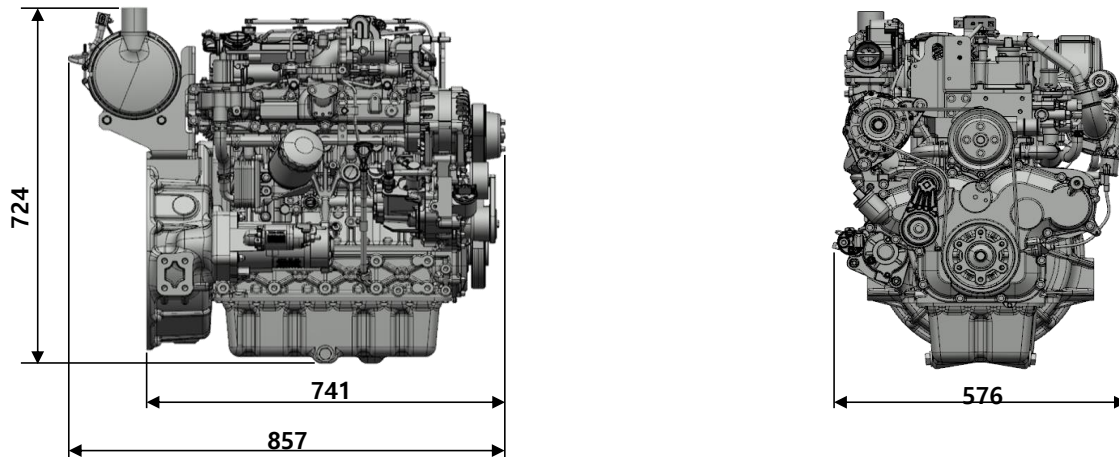

- Dimension (L×W×H) 1,185 × 629 × 959 mm (with powerpack)

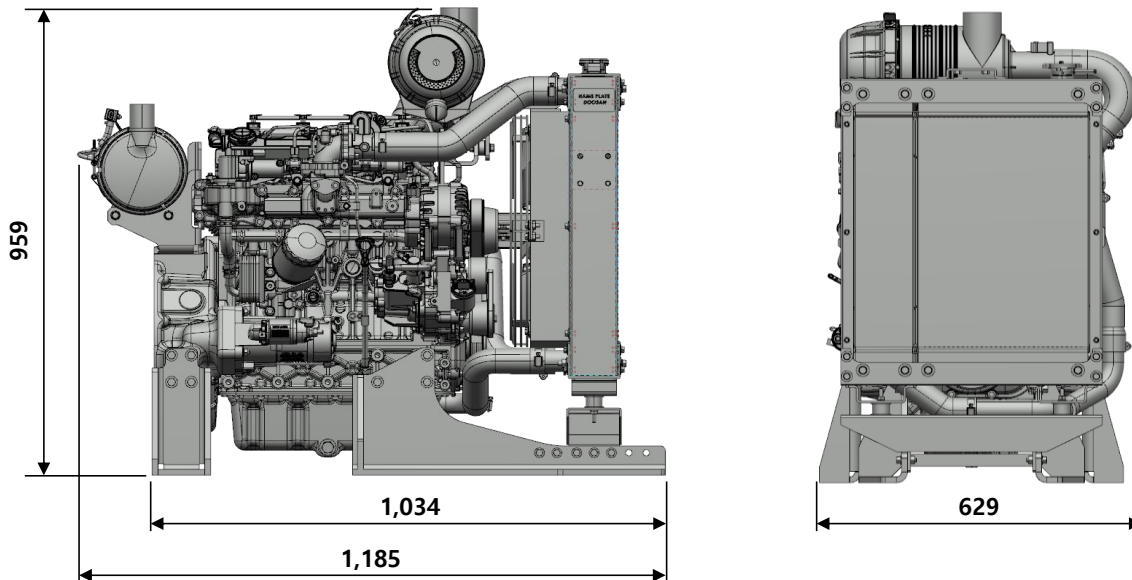

## ◆ Conversion Table

in. = mm x 0.0394	hp = PS x 0.98635	kW = 0.2388 kcal/s
PS = kW x 1.3596	lb = kg x 2.20462	lb/PS.h = g/kW.h x 0.00162
psi = kg/cm <sup>2</sup> x 14.2233	lb/ft = N.m x 0.737	cfm = m <sup>3</sup> /min x 35.336
in <sup>3</sup> = lit. x 61.02	U.S. gal = lit. x 0.264	

### HD Hyundai Infracore Co., Ltd.

489 Injung-ro, Dong-gu, Incheon, Republic of Korea (22502)

Email : enginesales@hyundai-di.com

Website : <https://www.hd-hyundaiengine.com/>

