

◎ POWER RATING

Engine Speed rev/min	Type of Operation	Engine Power	
		kWm	Ps
1800	Prime Power	270	367
	Standby Power	297	404
1500	Prime Power	230	313
	Standby Power	253	344



Note : -. The engine performance corresponds to ISO 3046, BS 5514 and DIN 6271.

* Without cooling fan, inter cooler inlet water temperature 32 °C

-. Ratings are based on ISO 8528.

→ **Prime power** available at variable load. The permissible average power out put (during 24h period) shall not exceed 70% of the prime power rating. No overload is permitted.

→ **Standby power** available in the event of a main power network failure. No overload is permitted.

◎ MECHANICAL SYSTEM

○ Engine Type	V-type 4 cycle, water cooled Turbo charged & intercooled (water to air)
○ Combustion type	Stoichiometric, Premixed and spark ignited
○ Cylinder Type	Replaceable wet liner
○ Number of cylinders	8
○ Bore x stroke	128(5.04) x 142(5.59) mm(in.)
○ Displacement	14.618 (892.05) lit.(in ³)
○ Compression ratio	10.5 : 1
○ Firing order	1-5-7-2-6-3-4-8-1
○ Ignition timing	14° BTDC
○ Compression pressure	Above 28 kg/cm ² (398 psi) at 200rpm
○ Dry weight (Engine)	Approx. 1,230 kg (2,711 lb)
○ Dimension (Engine) (LxWxH)	1,587 x 1,238 x 1,455 mm (62.5 x 48.7 x 57.3 in.)
○ Rotation	Counter clockwise viewed from Flywheel
○ Fly wheel housing	SAE NO.1
○ Fly wheel	Clutch NO.14

◎ MECHANISM

○ Type	Over head valve
○ Number of valve	Intake 1, exhaust 1 per cylinder
○ Valve lashes at cold	Intake 0.3mm (0.0118 in.) Exhaust 0.4mm (0.0157 in.)

◎ VALVE TIMING

	Opening	Close
○ Intake valve	24 deg. BTDC	36 deg. ABDC
○ Exhaust valve	63 deg. BBDC	27 deg. ATDC

◎ FUEL CONSUMPTION

○ Prime (Nm ³ /hr)	1,500 rpm	1,800 rpm
25%	28.8	34.3
50%	39.0	45.5
75%	48.2	57.6
90%	54.2	64.5
100%	58.4	68.8

○ Standby (Nm ³ /hr)	1,500 rpm	1,800 rpm
100%	63.2	72.5

◎ FUEL SYSTEM

○ Carburetor	Impco 200M Varifuel carburetor (2EA)
○ Gas regulator	Maxitrol RV61 (2EA)
○ Max. inlet pressure	1.0 psi at the engine inlet

◎ LUBRICATION SYSTEM

○ Lub. Method	Fully forced pressure feed type
○ Oil pump	Gear type driven by crankshaft
○ Oil filter	Full flow, cartridge type
○ Oil pan capacity	High level 31 liters (8.19 gal.) Low level 25 liters (6.60 gal.)
○ Lub. Oil	Refer to Operation Manual Low ash type(0.5wt%) natural gas engine oil API service grade CD or higher SAE 15W-40

◎ COOLING SYSTEM

- Cooling method Fresh water forced circulation
- Water capacity 36 liters (9.51 gal.) (Engine only)
- Pressure system Max. 0.5 kg/cm² (7.1 psi)
- Water pump Centrifugal type driven by belt
- Cooling fan Blower, 915mm diameter, 7 blades
Plastic
- Loss power of fan 22PS(16.2kW) @ Eng. Speed 1,500 rpm
33PS(24.3kW) @ Eng. Speed 1,800 rpm
- Thermostat Wax – pellet type
Opening temp. 71°C
Full open temp. 85°C

◎ ELECTRICAL SYSTEM

- Charging generator 24V x 45A alternator
- Voltage regulator Built-in type IC regulator
- Starting motor 24V x 7.0kW
- Battery Voltage 24V
- Battery Capacity 200 AH (recommended)
- Ignition controller 12 or 24V DC
(min 8V DC at start, 32V DC max)

◎ IGNITION SYSTEM

- Spark plug NGK IFR7B-D, 0.4mm air gap
Champion RC78PYP, 0.38mm air gap
- Ignition controller Altronic CPU-95 unit (24V DC)
- Ignition coil Altronic 501 061 blue epoxy
individual coil
- Trigger system Magnetic pick-up sensor and trigger
wheel and Hall-effect
(0.5/ 0.5/ 1.0mm air gap)

◎ ENGINEERING DATA

- Water flow 570 liters/min @1,500 rpm
680 liters/min @1,800 rpm
- Heat rejection to coolant 55 kcal/sec @1,500 rpm
68 kcal/sec @1,800 rpm
- Heat rejection to CAC 3.1 kcal/sec @1,500 rpm
4.7 kcal/sec @1,800 rpm
- Inter cooler water flow 290 liters/min @1,500 rpm
340 liters/min @1,800 rpm
- Air flow 18.5 m³/min @1,500 rpm
22.9 m³/min @1,800 rpm
- Exhaust gas flow 30.0 m³/min @1,500 rpm
37.8 m³/min @1,800 rpm
- Exhaust gas temp. 495 °C @1,500 rpm
520 °C @1,800 rpm
- Radiator air flow 550 m³/min @1,500 rpm, 0.7kPa
650 m³/min @1,800 rpm, 1kPa
- Max. permissible restrictions
 - Intake system 220 mmH₂O initial
635 mmH₂O final
 - Exhaust system 600 mmH₂O max.
- Altitude Capability 1,000 m

◆ CONVERSION TABLE

- | | |
|---|------------------------------------|
| in. = mm x 0.0394 | lb/ft = N.m x 0.737 |
| PS = kW x 1.3596 | U.S. gal = lit. x 0.264 |
| psi = kg/cm ² x 14.2233 | kW = 0.2388 kcal/s |
| in ³ = lit. x 61.02 | lb/PS.h = g/kW.h x 0.00162 |
| hp = PS x 0.98635 | cfm = m ³ /min x 35.336 |
| lb = kg x 2.20462 | Nm ³ = SCF × 0.0283 |
| Kg/hr = Nm ³ /hr × 0.732 (natural gas) | |
| Btu/ft ³ = MJ/m ³ × 26.8392 (natural gas) | |
| kPa = 101.97 mmH ₂ O = 0.01 bar | |

© Dimensions : Engine

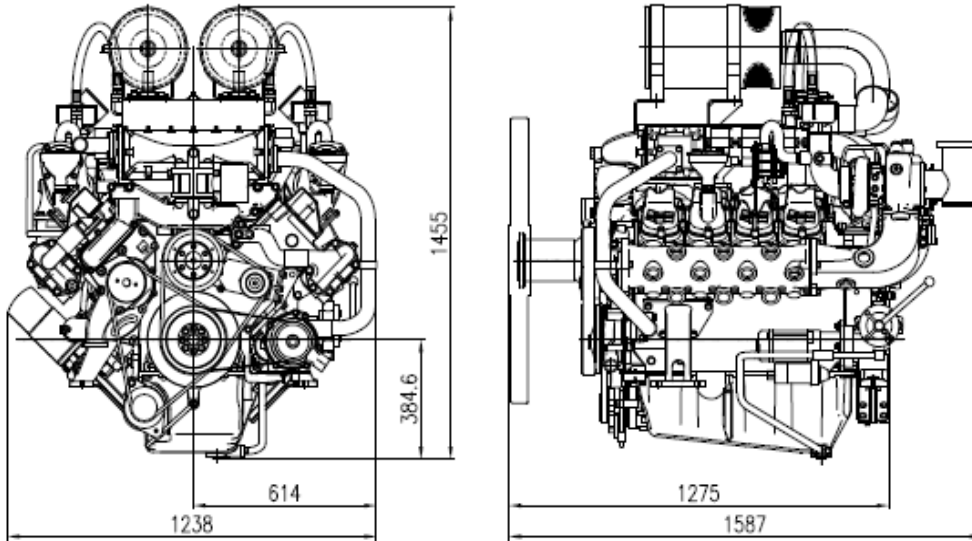

© Dimensions : Gen-pack

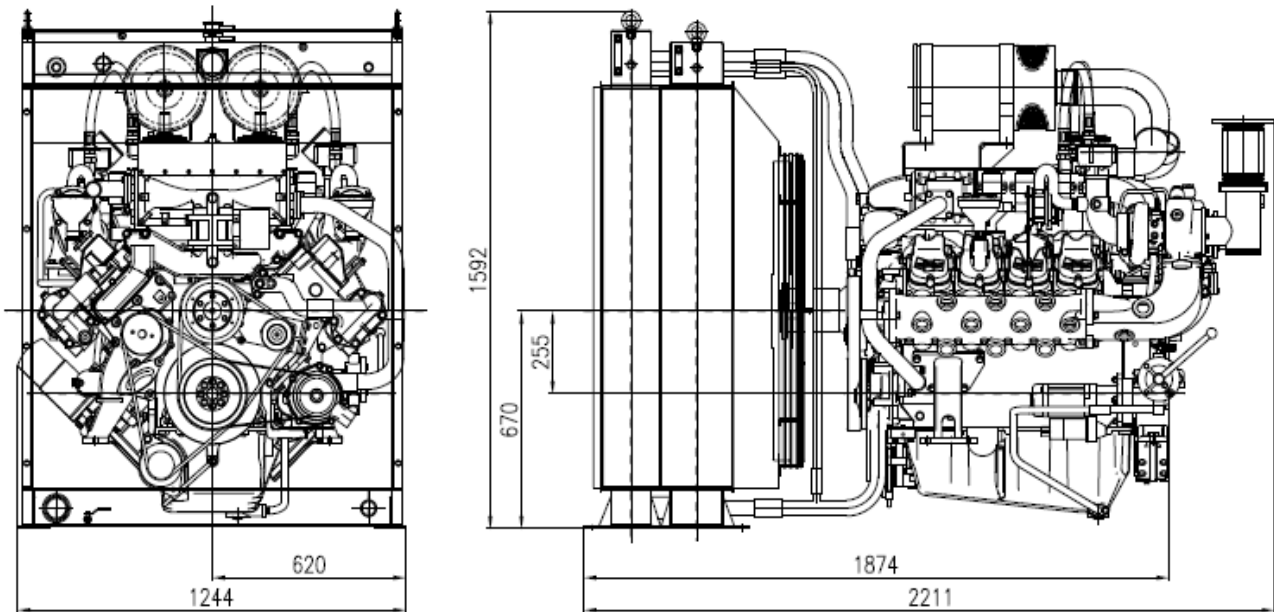

Doosan Infracore Co., Ltd.

21st Floor, Doosan Tower, 18-12, Euljiro 6-ga,
Jung-gu, Seoul, Korea

TEL : +82-2-3398-8400 / Fax : +82-2-3398-8509

E-mail : enginesales@doosan.com

Web site : www.doosaninfracore.com

※ Specifications are subject to change without prior notice